

**SPLIT SYSTEM WITH LOW-NOISE
CONDENSING UNIT TECHNICAL DATA
SHEET DORIN H151CS**

TECHNICAL DATA	
Code	ISSL031ASD
Type	Low-noise (1100)
Noise	35 dBA 10m
Application	Low Temp.
Expansion	Valve
Refrigerant	R452A
CAT. PED	1
CONDENSING UNIT DIMENSIONS	
Width W	1155
Depth D	450
Height H	750
Net weight	154 kg
PIPE FITTINGS	
Liquid line	Ø 10
Suction	Ø 16
ABSORPTION	
Power consumption (W)	1606 (W)
Current consumption (A)	4 (A)
Power defrost (W)	1290 (W)
CONDENSER	
Condensation	Aria
Fans no.	1
Diameter	Ø 400
RPM	900 g/m
EVAPORATOR	
Fans no.	2
Diameter	Ø 250
Air flow	2128 m3/h
Air throw	9 m
COMPRESSOR	
Type	SEMI-HERMETIC
Compressors no.	1 H151CS
Brand	DORIN
Voltage	380-420 V
Displacement	7,5 (cc)



Indicative product image



LED lamp



Door micro-switch

**REFRIGERATION CAPACITY TABLE (W - M³) OF SPLIT SYSTEM
WITH LOW-NOISE CONDENSING UNIT DORIN H151CS Refrigerant R452A**

COLD ROOM T.	-15 °C		-20 °C		-25 °C	
AMBIENT T.	W	M ³	W	M ³	W	M ³
25 °C	2219	22,1	1872	18,0	1551	12,1
32 °C	2050	19,7	1723	15,9	1421	10,6
38 °C	1881	16,5	1571	13,2	1285	8,8
43 °C	1747	13,3	1455	10,6	1184	6,9

EVAPORATOR DIMENSIONS

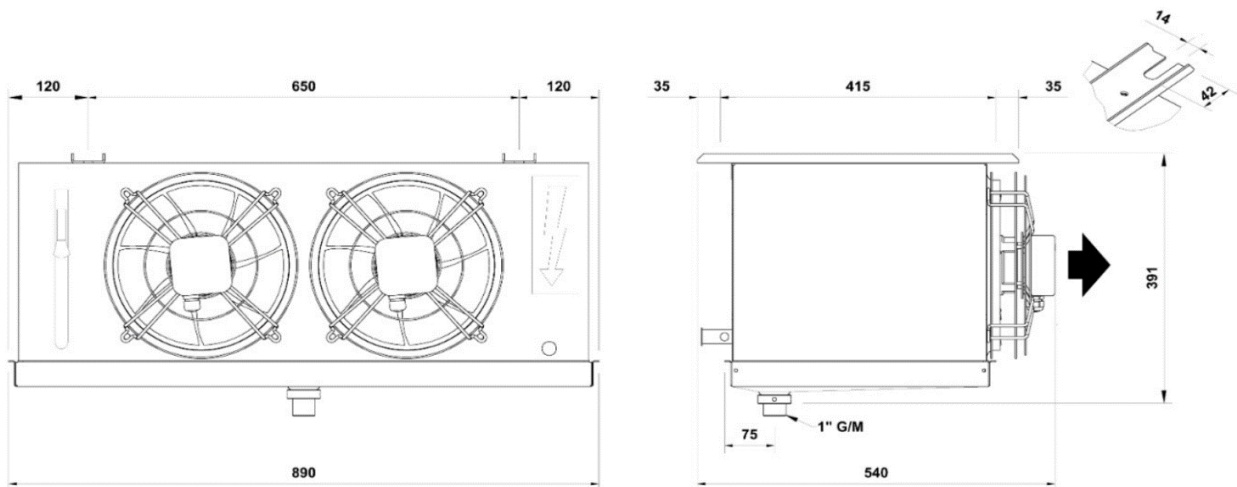

STANDARD TECHNICAL FEATURES

- Self-supporting casing in zinc-plated metal sheet coated with epoxy powder (RAL7047);
- Sound insulation on the compressor side;
- Semi-hermetic compressor with internal protection of the motor;
- Compressor muffler;
- High-performance air condenser with aluminium fins and grooved cooper tubes;
- Axial external rotor fan-motor (900 rpm) 220V_50Hz;
- Condenser fan speed regulator;
- Liquid receiver with safety valve;
- Drier filter to be welded;
- Humidity indicator to be welded;
- Solenoid valve on the liquid line to welded;
- HP+LP pressure switch with automatic reset;
- Rapid shut-off valves up to d.18mm; shut-off valves to be welded from d.22mm on;
- Built-in power and control electrical box;
- Aluminium and copper ventilated evaporator with electric defrost;
- Expansion by thermostatic valve;
- Condensed water tray (tube heater for low temperature models);
- Condenser - evaporator connecting cables, cable length 2,5 meters;
- Wired remote control panel with large display, cable length 2,5 meters;
- Wired door micro-switch, cable length 2,5 meters;
- Cold room light with wired LED lamp, cable length 2,5 meters;
- Power cable length 2,5 meters;
- Condensing unit under nitrogen pressure;
- PED directive compliant units;
- Packaging included (pallet+cardboard);

OPTIONAL ON REQUEST

- Wi-Fi module for remote management;
- Compressor crankcase heater;
- Oil separator;
- Liquid separator;
- Refrigerant charge;
- Cables kit for evaporator, cold room light, door micro-switch and remote panel (from 5 to 30 meters);
- Cable kit for remote control panel (from 5 to 30 meters);
- Pipe connections SAE flare kit up to Ø18 in suction (from 2,5 to 30 meters);
- Pre-charged pipe connections kit up to Ø18 in suction (from 2,5 to 30 meters);
- Pipe connections kit to be welded up to Ø18 in suction (from 2,5 to 30 meters);
- Water condensation or mixed air/water condensation;
- Cataphoresis treatment on evaporator and/or on condenser;
- Electrical fan;
- Packaging with wooden cage;