

SPLIT UNIT TECHNICAL DATA SHEET

Technical data

Type	Low noise Split
Code	ISSL051AET
Condensation	Air
Net weight	123 Kg
PED	1
Defrost	Electrical
Expansion	Valve
Application	LBP
Refrigerant	R452A

Dimensions

Width L	800
Depth P	400
Height H	610

Pipe fittings

Liquid diam.	10 mm
Suction diam.	16 mm

Absorptions

Power consumption	1538 W
Current consumption	4.3 A
Power defrost	1950 W

Condenser

Fans no.	1
Diameter	350 mm
Air flow	1945 m ³ /h

Evaporator

Fans no.	2
Diameter	300 mm
Air flow	2875 m ³ /h
Air throw	11 m

Compressor

Type	Hermetic
Compressors no.	1 (TFH2480Z)
Brand	TECUMSEH
Voltage	400/3/50
Displacement	53.2 cm ³ - 2 hp



Indicative product image



LED light



Magnetic door micro-switch

Table of Split unit cooling capacities in W - R452A

AMBIENT T.	COLD ROOM T.					
	-15°C		-20°C		-25°C	
	W	m ³	W	m ³	W	m ³
25°C	2665	33,4	2225	23,3	1816	15,9
32°C	2407	25,7	1992	17,9	1605	12
38°C	2127	19,8	1724	13,4	1348	8,8
43°C	1927	16	1546	10,7	1189	6,8

Evaporator dimensions

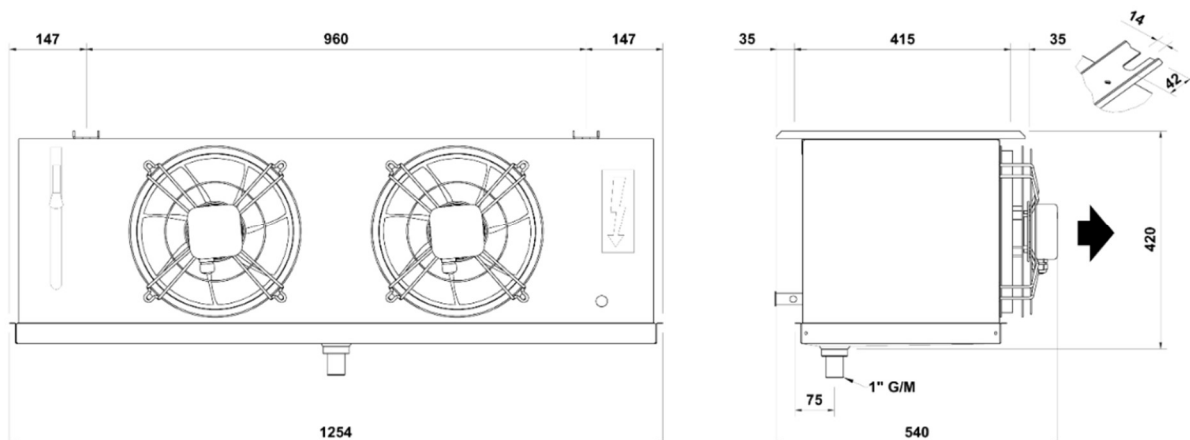

Technical features (standard)

- Structure in zinc-plated metal sheet coated with epoxy primer and powder;
- Sound insulation;
- Internal arrangement of components designed to facilitate maintenance;
- Heat exchangers with copper tubes and aluminium fins;
- Air condensation;
- Air evaporation;
- Electrical defrost;
- Liquid receiver;
- Drier filter;
- Liquid indicator;
- Solenoid valve on the liquid line;
- High-pressure switch (automatic reset/fixed setting);
- Condensing unit under nitrogen pressure;
- Electronic control unit;
- **Expansion by thermostatic valve;**
- **Low-pressure switch (automatic reset);**
- **Condenser fan speed control with pressure speed variator;**
- **Control unit designed for remote management via Wi-Fi module (optional);**
- **Fans evaporator + defrost heaters Cable L=10m;**
- **Evaporator temp. probes + cold room Cable L=10m**
- **Cold room light with cable L=10m;**
- **Magnetic micro-switch with cable L = 10m;**
- **Remote control panel with cable 10m;**
- **Power cable L=2,5m;**
- **Packaging with wooden pallet and cardboard (included);**

Optional on request

- Refrigerant charge without piping;
- Pipes for evaporator connection L= 5/10/15/20/30m;
- Oil separator;
- Liquid separator;
- Compressor crankcase heater;
- Wi-Fi module for remote management;
- Remote control panel with cable L= 15/20/30m;
- Length increase for machine's power cables, light cable, door micro-switch cable and remote control panel (15/20/30m);
- Voltage monitor for three-phase application;
- Cataphoresis treatment on evaporator and/or condenser;
- Packaging with wooden cage;