

**SPLIT SYSTEM WITH LOW-NOISE
CONDENSING UNIT TECHNICAL DATA
SHEET DORIN H221CS**

TECHNICAL DATA

Code	ISSL061ASD
Type	Low-noise (1100)
Noise	35 dBA 10m
Application	Low Temp.
Expansion	Valve
Refrigerant	R452A
CAT. PED	1

CONDENSING UNIT DIMENSIONS

Width W	1155
Depth D	450
Height H	750
Net weight	167 kg

PIPE FITTINGS

Liquid line	Ø 10
Suction	Ø 18

ABSORPTION

Power consumption (W)	2330 (W)
Current consumption (A)	5,8 (A)
Power defrost (W)	1950 (W)

CONDENSER

Condensation	Aria
Fans no.	1
Diameter	Ø 400
RPM	900 g/m

EVAPORATOR

Fans no.	2
Diameter	Ø 300
Air flow	2793 m3/h
Air throw	10 m

COMPRESSOR

Type	SEMI-HERMETIC
Compressors no.	1 H221CS
Brand	DORIN
Voltage	380-420 V
Displacement	10,61 (cc)



Indicative product image



LED lamp



Door micro-switch

**REFRIGERATION CAPACITY TABLE (W - M³) OF SPLIT SYSTEM
WITH LOW-NOISE CONDENSING UNIT DORIN H221CS Refrigerant R452A**

COLD ROOM T.	-15 °C		-20 °C		-25 °C	
AMBIENT T.	W	M ³	W	M ³	W	M ³
25 °C	3254	43,5	2750	35,5	2282	24,4
32 °C	2973	38,5	2501	30,9	2062	21,0
38 °C	2668	32,8	2216	25,8	1797	17,3
43 °C	2454	27,1	2029	20,7	1637	13,5

EVAPORATOR DIMENSIONS

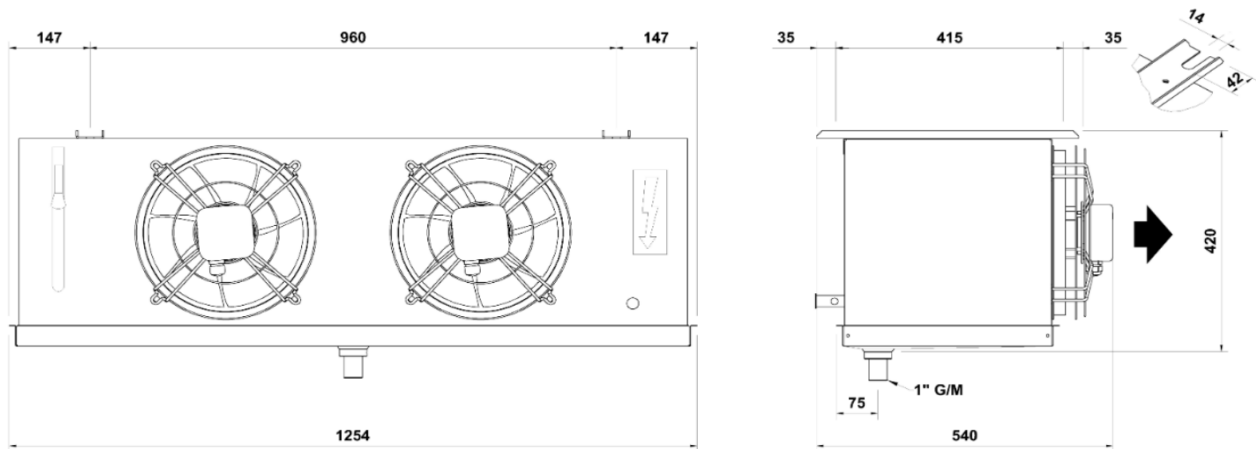

STANDARD TECHNICAL FEATURES

- Self-supporting casing in zinc-plated metal sheet coated with epoxy powder (RAL7047);
- Sound insulation on the compressor side;
- Semi-hermetic compressor with internal protection of the motor;
- Compressor muffler;
- High-performance air condenser with aluminium fins and grooved cooper tubes;
- Axial external rotor fan-motor (900 rpm) 220V_50Hz;
- Condenser fan speed regulator;
- Liquid receiver with safety valve;
- Drier filter to be welded;
- Humidity indicator to be welded;
- Solenoid valve on the liquid line to welded;
- HP+LP pressure switch with automatic reset;
- Rapid shut-off valves up to d.18mm; shut-off valves to be welded from d.22mm on;
- Built-in power and control electrical box;
- Aluminium and copper ventilated evaporator with electric defrost;
- Expansion by thermostatic valve;
- Condensed water tray (tube heater for low temperature models);
- Condenser - evaporator connecting cables, cable length 2,5 meters;
- Wired remote control panel with large display, cable length 2,5 meters;
- Wired door micro-switch, cable length 2,5 meters;
- Cold room light with wired LED lamp, cable length 2,5 meters;
- Power cable length 2,5 meters;
- Condensing unit under nitrogen pressure;
- PED directive compliant units;
- Packaging included (pallet+cardboard);

OPTIONAL ON REQUEST

- Wi-Fi module for remote management;
- Compressor crankcase heater;
- Oil separator;
- Liquid separator;
- Refrigerant charge;
- Cables kit for evaporator, cold room light, door micro-switch and remote panel (from 5 to 30 meters);
- Cable kit for remote control panel (from 5 to 30 meters);
- Pipe connections SAE flare kit up to Ø18 in suction (from 2,5 to 30 meters);
- Pre-charged pipe connections kit up to Ø18 in suction (from 2,5 to 30 meters);
- Pipe connections kit to be welded up to Ø18 in suction (from 2,5 to 30 meters);
- Water condensation or mixed air/water condensation;
- Cataphoresis treatment on evaporator and/or on condenser;
- Electrical fan;
- Packaging with wooden cage;