

#### TECHNICAL DATA

Code	ISSL161ASD
Type	Low-noise (1400)
Noise	41,5 dBA 10m
Application	Low Temp.
Expansion	Valve
Refrigerant	R452A
CAT. PED	1

#### CONDENSING UNIT DIMENSIONS

Width W	1460
Depth D	650
Height H	1190
Net weight	370 kg

#### PIPE FITTINGS

Liquid line	Ø 12
Suction	Ø 28

#### ABSORPTION

Power consumption (W)	6500 (W)
Current consumption (A)	16,2 (A)
Power defrost (W)	6450 (W)

#### CONDENSER

Condensation	Aria
Fans no.	2
Diameter	Ø 450
RPM	900 g/m

#### EVAPORATOR

Fans no.	3
Diameter	Ø 350
Air flow	6752 m3/h
Air throw	15 m

#### COMPRESSOR

Type	SEMI-HERMETIC
Compressors no.	1 H705CS
Brand	DORIN
Voltage	380-420 V
Displacement	31,88 (cc)

### SPLIT SYSTEM WITH LOW-NOISE CONDENSING UNIT TECHNICAL DATA SHEET DORIN H705CS



Indicative product image



LED lamp



Door micro-switch

**REFRIGERATION CAPACITY TABLE (W - M<sup>3</sup>) OF SPLIT SYSTEM  
WITH LOW-NOISE CONDENSING UNIT DORIN H705CS Refrigerant R452A**

COLD ROOM T.	-15 °C		-20 °C		-25 °C	
	W	M <sup>3</sup>	W	M <sup>3</sup>	W	M <sup>3</sup>
25 °C	10043	235,1	8534	202,4	7127	136,4
32 °C	9209	207,4	7797	178,9	6478	124,2
38 °C	8329	180,4	6985	153,8	5730	103,6
43 °C	7671	153,3	6412	128,7	5236	82,9

**EVAPORATOR DIMENSIONS**

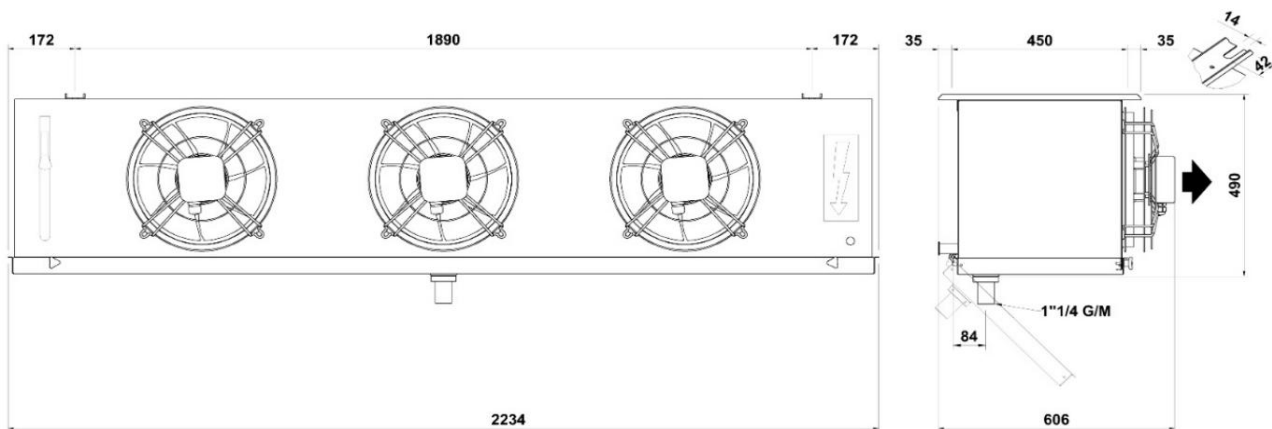

## STANDARD TECHNICAL FEATURES

- Self-supporting casing in zinc-plated metal sheet coated with epoxy powder (RAL7047);
- Sound insulation on the compressor side;
- Semi-hermetic compressor with internal protection of the motor;
- Compressor muffler;
- High-performance air condenser with aluminium fins and grooved cooper tubes;
- Axial external rotor fan-motor (900 rpm) 220V\_50Hz;
- Condenser fan speed regulator;
- Liquid receiver with safety valve;
- Drier filter to be welded;
- Humidity indicator to be welded;
- Solenoid valve on the liquid line to welded;
- HP+LP pressure switch with automatic reset;
- Rapid shut-off valves up to d.18mm; shut-off valves to be welded from d.22mm on;
- Built-in power and control electrical box;
- Aluminium and copper ventilated evaporator with electric defrost;
- Expansion by thermostatic valve;
- Condensed water tray (tube heater for low temperature models);
- Condenser - evaporator connecting cables, cable length 2,5 meters;
- Wired remote control panel with large display, cable length 2,5 meters;
- Wired door micro-switch, cable length 2,5 meters;
- Cold room light with wired LED lamp, cable length 2,5 meters;
- Power cable length 2,5 meters;
- Condensing unit under nitrogen pressure;
- PED directive compliant units;
- Packaging included (pallet+cardboard);

## OPTIONAL ON REQUEST

- Wi-Fi module for remote management;
- Compressor crankcase heater;
- Oil separator;
- Liquid separator;
- Refrigerant charge;
- Cables kit for evaporator, cold room light, door micro-switch and remote panel (from 5 to 30 meters);
- Cable kit for remote control panel (from 5 to 30 meters);
- Pipe connections SAE flare kit up to Ø18 in suction (from 2,5 to 30 meters);
- Pre-charged pipe connections kit up to Ø18 in suction (from 2,5 to 30 meters);
- Pipe connections kit to be welded up to Ø18 in suction (from 2,5 to 30 meters);
- Water condensation or mixed air/water condensation;
- Cataphoresis treatment on evaporator and/or on condenser;
- Electrical fan;
- Packaging with wooden cage;