

## SPLIT UNIT TECHNICAL DATA SHEET

### Technical data

Type	Low noise Split
Code	ISSM061AET
Condensation	Air
Net Weight	101 Kg
PED	1
Defrost	Electrical
Expansion	Valve
Application	MBP
Refrigerant	R452A

### Dimensions

Width L	800
Depth P	400
Height H	610

### Pipe fittings

Liquid diam.	10 mm
Suction diam.	12 mm

### Absorptions

Power consumption	1282 W
Current consumption	6,02 A
Power defrost	1020 W

### Condenser

Fans no.	1
Diameter	350 mm
Air flow	1699 m <sup>3</sup> /h

### Evaporator

Fans no.	3
Diameter	250 mm
Air flow	1780 m <sup>3</sup> /h
Air throw	5 m

### Compressor

Type	Hermetic
Compressors no.	1 (CAJ9513Z)
Brand	TECUMSEH
Voltage	220-240/1/50
Displacement	24,2 cm <sup>3</sup> - 1 hp



Indicative product image



LED light



Magnetic door micro-switch

### Versions

- Standard vers. with angular evaporator;
- Cubic evaporator vers.;
- Double flow evaporator vers.;

**Table of Split unit cooling capacities in W - R452A**

AMBIENT T.	COLD ROOM T.					
	5°C		0°C		-5°C	
	W	m <sup>3</sup>	W	m <sup>3</sup>	W	m <sup>3</sup>
25°C	2843	38,1	2464	26,3	2106	18,2
32°C	2583	27,7	2232	19,5	1901	13,7
38°C	2348	21,2	2025	15	1718	10,6
43°C	2144	16,7	1844	11,9	1559	8,4

### Evaporator dimensions

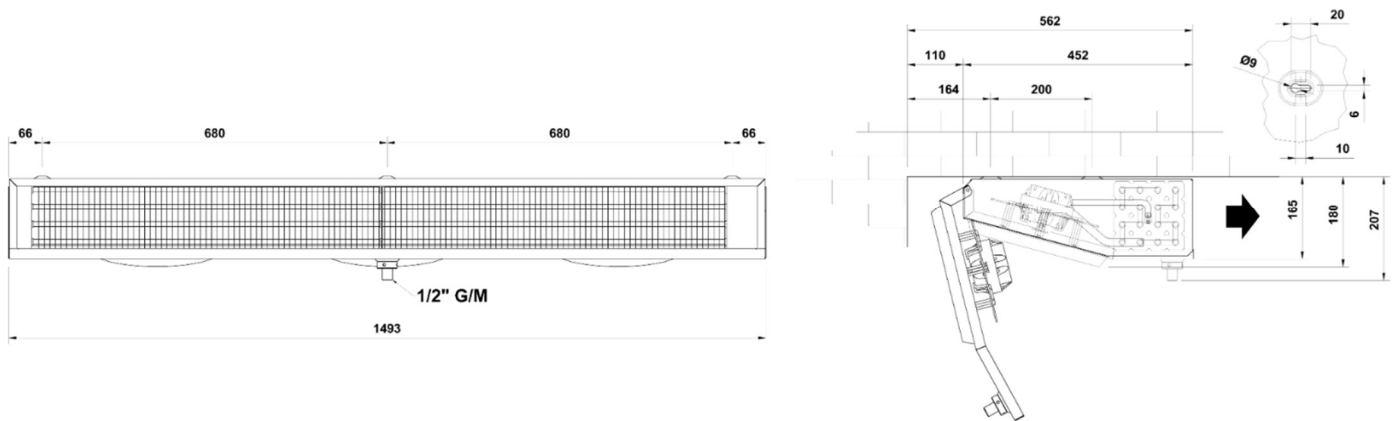

### Technical features (standard)

- Structure in zinc-plated metal sheet coated with epoxy primer and powder;
- Sound insulation;
- Internal arrangement of components designed to facilitate maintenance;
- Heat exchangers with copper tubes and aluminium fins;
- Air condensation;
- Air evaporation;
- Electrical defrost;
- Liquid receiver;
- Drier filter;
- Liquid indicator;
- Solenoid valve on the liquid line;
- High-pressure switch (automatic reset/fixed setting);
- Condensing unit under nitrogen pressure;
- Electronic control unit;
- **Expansion by thermostatic valve;**
- **Low-pressure switch (automatic reset);**
- **Condenser fan speed control with pressure speed variator;**
- **Control unit designed for remote management via Wi-Fi module (optional);**
- **Fans evaporator + defrost heaters Cable L=10m;**
- **Evaporator temp. probes + cold room Cable L=10m**
- **Cold room light with cable L=10m;**
- **Magnetic micro-switch with cable L = 10m;**
- **Remote control panel with cable 10m;**
- **Power cable L=2,5m;**
- **Packaging with wooden pallet and cardboard (included);**

### Optional on request

- Refrigerant charge without piping;
- Pipes for evaporator connection L= 5/10/15/20/30m;
- Oil separator;
- Liquid separator;
- Compressor crankcase heater;
- Wi-Fi module for remote management;
- Remote control panel with cable L= 15/20/30m;
- Length increase for machine's power cables, light cable, door micro-switch cable and remote control panel (15/20/30m);
- Voltage monitor for three-phase application;
- Cataphoresis treatment on evaporator and/or condenser;
- Packaging with wooden cage