

SPLIT UNIT TECHNICAL DATA SHEET

Technical data

Type	Low noise Split
Code	ISSM091AET
Condensation	Air
Net Weight	117 Kg
PED	1
Defrost	Electrical
Expansion	Valve
Application	MBP
Refrigerant	R452A

Dimensions

Width L	1100
Depth P	400
Height H	750

Pipe fittings

Liquid diam.	10 mm
Suction diam.	16 mm

Absorptions

Power consumption	1945 W
Current consumption	9,36 A
Power defrost	1950 W

Condenser

Fans no.	1
Diameter	400 mm
Air flow	2610 m ³ /h

Evaporator

Fans no.	2
Diameter	300 mm
Air flow	2875 m ³ /h
Air throw	11 m

Compressor

Type	Hermetic
Compressors no.	1 (AJ4519Z)
Brand	TECUMSEH
Voltage	220-240/1/50
Displacement	34,45 cm ³ - 1,5hp



Indicative product Image



LED light



Magnetic door micro-switch

Versions

- Standard vers. with angular evaporator;
- Cubic evaporator vers.;
- Double flow evaporator vers.;

Table of Split unit cooling capacities in W - R452A

AMBIENT T.	COLD ROOM T.					
	5°C		0°C		-5°C	
	W	m ³	W	m ³	W	m ³
25°C	3911	54,5	3409	38,3	2934	27
32°C	3579	40,5	3112	28,9	2669	20,7
38°C	3271	31,3	2840	22,6	2428	16,2
43°C	2998	25,2	2599	18,3	2215	13,1

Evaporator dimensions

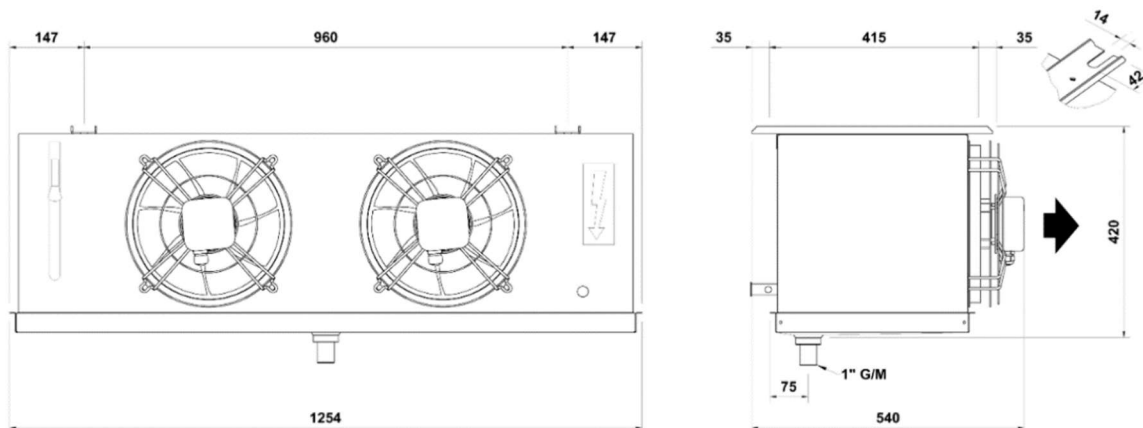

Technical features (standard)

- Structure in zinc-plated metal sheet coated with epoxy primer and powder;
- Sound insulation;
- Internal arrangement of components designed to facilitate maintenance;
- Heat exchangers with copper tubes and aluminium fins;
- Air condensation;
- Air evaporation;
- Electrical defrost;
- Liquid receiver;
- Drier filter;
- Liquid indicator;
- Solenoid valve on the liquid line;
- High-pressure switch (automatic reset/fixed setting);
- Condensing unit under nitrogen pressure;
- Electronic control unit;
- **Expansion by thermostatic valve;**
- **Low-pressure switch (automatic reset);**
- **Condenser fan speed control with pressure speed variator;**
- **Control unit designed for remote management via Wi-Fi module (optional);**
- **Fans evaporator + defrost heaters Cable L=10m;**
- **Evaporator temp. probes + cold room Cable L=10m**
- **Cold room light with cable L=10m;**
- **Magnetic micro-switch with cable L = 10m;**
- **Remote control panel with cable 10m;**
- **Power cable L=2,5m;**
- **Packaging with wooden pallet and cardboard (included);**

Optional on request

- Refrigerant charge without piping;
- Pipes for evaporator connection L= 5/10/15/20/30m;
- Oil separator;
- Liquid separator;
- Compressor crankcase heater;
- Wi-Fi module for remote management;
- Remote control panel with cable L= 15/20/30m;
- Length increase for machine's power cables, light cable, door micro-switch cable and remote control panel (15/20/30m);
- Voltage monitor for three-phase application;
- Cataphoresis treatment on evaporator and/or condenser;
- Packaging with wooden cage